

Hamtronix

MICROCONTROLLED DEVICES

CRD300 DTMF/Serial Remote Control Board

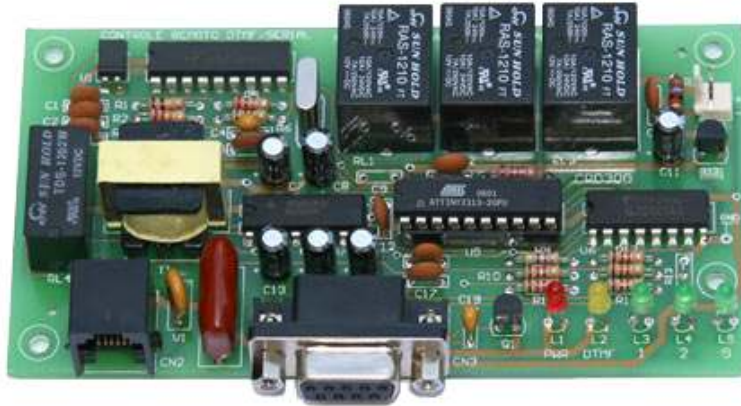

Instruction Manual

Version 2.0
Hardware Revision C

November/2008

Index

Technical Support	01
Precautions	01
Warranty	01
About This Product	02
Suggestions to Use	02
The Board	03
Installation Over a Telephone Land Line	04
Installation Over a Cellular Phone	04
Installation Over A Radio Transceiver	05
Installation Over A Serial Port.....	06
Maximum Allowed Voltage and Power	07
Power Supply For The CRD300.....	07
Operation Over A Telephone Land Line.....	08
Operation Over A Cellular Phone	09
Operation Over A Radio Transceiver.....	10
Operation Over A RS232 Serial Port	11
Command List By Radio Or Telephone	12
Command List By Serial Port	13
Changing The Number Of Rings For Auto-Answer.....	14
Changing Password	14
PTT/Output 4 Selection	14
OUTPUTS BACKUP	14
Monitoring Inputs.....	15
CN3 Connector.....	16
Troubleshooting – Master Reset	17

Technical Support

If any doubt remains after a complete reading of this manual, visit our web site. You will find last minute information and an FAQ section with answers to frequent questions. You can get support by e-mail:

support@hamtronix.com

Questions by e-mail are usually answered in less than 24 hours.

Precautions

Please observe the following precaution to prevent damages:

Verify the correct polarity of the power source. Incorrect polarity may destroy the board.

Do not modify **CRD300** circuits unless instructed by this manual or by Hamtronix documentation.

Do not place the board in excessively dusty areas, humid areas, wet areas, nor on unstable surfaces that may cause short-circuits.

When interfacing with external circuits, pay special attention to the maximum limits of voltages and currents.

Warranty

This Warranty covers all defects in materials and workmanship in Hamtronix boards for the original purchaser. This Warranty will remain in effect for one (1) year from the date of purchase by the original purchaser. This Warranty do not covers damage, deterioration or failure resulting from: 1) accident, misuse, abuse, neglect, unauthorized product modification or failure to follow instruction contained in the manual; 2) Water or other elements; 3) Repair or attempted repair by anyone not authorized by Hamtronix. 4) Any unit which is not new when sold to the first end user or upon which the serial number has been defaced, modified or removed.

This board must be interconnected through connectors. Any sign of direct soldering to the board will void the Warranty.

Hamtronix liability is limited to repair or replacement of any defective product, Hamtronix shall not be liable for any damages, whether incidental, consequential or otherwise, because of any defective Hamtronix product.

If it is necessary to ship the product to us for warranty service, you are responsible for the shipping charges.

About This Product

We developed this board to supply a reliable and affordable way to remotely control appliances and any kind of electric equipment through the telephone line, cellular phone, radio or PC serial port (RS232).

When the **CRD300** board is connected to a 12V power supply and your relays connected to your electric devices, you can control up to three independent outputs with the following commands:

- Turn an output Off
- Turn an output On
- Pulse an output
- Turn an output off and automatically turn on after period of time.
- Read the output status

The **CRD300** offers a great variety of ways of communication to allow you to control your devices. It can be interface with a telephone line, a cellular phone, a radio receiver or even through your PC serial port. The late can allow you to take control of your devices via LAN or Internet (requires a third part hardware and software).

Suggestion to Use

There are a number of uses for a device like this, but one area where it is of great help is for Wireless Internet Service Providers. These providers normally have equipments installed in hills, tall buildings, towers and other hard to reach places. And it is quite common those devices to freeze and the only way to bring them back to life will be recycling the power.

When this happen, without a **CRD300**, the only solution may be drive to the site and restart the equipment. Now, you can deal with this situation just making a phone call. You don't waste your time and money driving long distances anymore.

The **CRD300** can be used to reset computer servers or any kind of electric equipment without your presence at the installation site.

There are a number of applications where you can use the outputs or even the inputs of the **CRD300**, as in alarms, lights, gates, etc. You can use in home, at your business or industry. Just use your imagination.

The Board

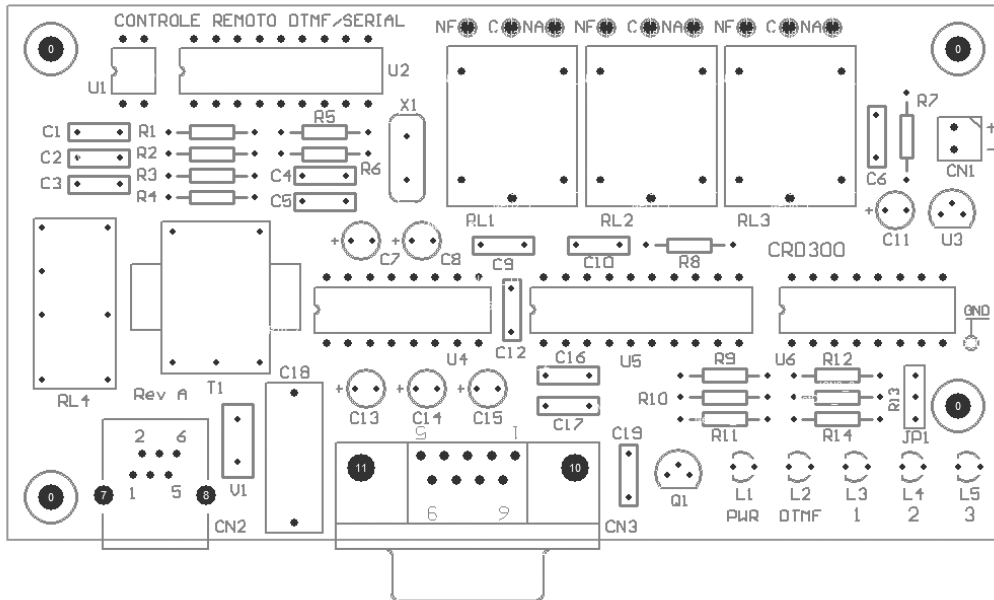

Connectors

The **CRD300** feature three connectors: CN1 for 12V¹ DC power, CN2 for telephone line and CN3 for PC serial, cellular, radio and monitoring inputs. See details on page 16.

LEDs

The LED **PWR** will be on when the 12V is connected to the board and will blink to confirm commands.

The **DTMF** LED will be on during DTMF receiving commands through the radio or telephone.

LEDs **1**, **2** and **3** will be on indicating the state of the respective output.

Relay connections²

In the back, behind each relay, there are connections for each relay contact with the external world. Each relay have available C (common), NC (normally closed) e NO (Normally Open). Utilize one or more as your application needs.

Note

¹ Pay special attention to the power supply polarity. If inverted, the board circuits will be damaged and the warranty will not cover this occurrence.

Installation

The **CRD300** can be used over a variety of DTMF sources. See the options and how to install in each case:

Installation Over A Telephone Land Line

- 1) Connect the telephone line to the CN2 phone Jack;
- 2) Connect the desired loads to the relays you want to use;
- 3) Connect a 12V Power supply or battery to CN1 connector.

See Page 8 to learn how to operate over land line.

Installation Over A Cellular Phone

To use the **CRD300** with a cellular phone, three signals from the cellular headset jack¹ are needed. These signals should be connected through the CN3² DB9 type connector as following:

- 1) Connect the audio source³ (headphone audio) to CN3 pin 1;
- 2) Connect the microphone audio³ (MIC) to CN3 pin 4;
- 3) Connect the GND³ (usually shield) to CN3 pin 5;
- 4) Set the cellular phone to auto-answer mode⁴;
- 5) Connect the desired loads to the relays you want to use;
- 6) Connect a 12V Power supply or battery to CN1 connector.

We recommend powering the cellular with a cellular charger all the time. This way the battery will have enough charge to avoid the cellular to power off, since most cellular phones will not power on itself when powered after a power fail.

See Page 9 to learn how to operate over cellular phones.

Notes

¹ *If you have problems to find the correct headset plug, just buy a cheap compatible headset, cut the cord and use it.*

² *A CN3 pin out illustration can be found in Page 17.*

³ *The audio signals needed are always available in the cellular headset jack, not being necessary any internal connections to the cellular phone.*

⁴ *Some cellular phones will only show and allow the auto-answer setup when the headset plug is connected.*

Installation Over A Radio Transceiver

There are places where neither cellular or land line are available. In those cases, the only way to communicate with the **CRD300** is using a VHF or UHF radio transceiver¹. Using a good irradiant system with enough power, may allow you to reach distances over 60 miles (100Km).

To connect the **CRD300** with a radio transceiver, four signals from the radio are needed. These signals should be connected through CN3 connector as following:

- 1) Connect the audio source (speaker audio) to CN3 pin 1;
- 2) Connect the microphone audio (MIC) to CN3 pin 4;
- 3) Connect the GND (usually shield) to CN3 pin 5;
- 4) Connect the PTT³ signal to CN3 pin 9;
- 5) Connect the desired loads to the relays you want to use;
- 6) Connect a 12V Power supply or battery to CN1 connector.

See Page 10 to learn how to operate over radio transceivers.

Radio and antenna installations should be performed by a radio amateur or by a communication technician.

Notes

¹ Many countries requires licenses to allow radio transceivers operations powers over 100mW.

² A CN3 pin out illustration can be found in Page 17.

³ PTT stands for Push To Talk. Normally grounding PTT signal will make the transceiver go to the transmission mode.

Installation Over A Serial Port (RS232)

The **CRD300** can be controlled through a RS232 serial port available in most computers or Ethernet to serial devices. This feature is handy in case you need control over the LAN or Internet¹.

To connect over the serial port, do the following:

- 1) Connect a serial cable² to CN3;
- 2) Connect the desired loads to the relays you want to use;
- 3) Connect a 12V Power supply or battery to CN1 connector.

See Page 11 to learn how to operate over serial RS232.

Notes

¹ To operate over a local network or Internet, a terminal software like Windows Hyperterminal is needed. This software is not supplied by Hamtronix and should be downloaded over Internet.

² As the **CRD300** operates as DCE (Data Communication Equipment), you only need a simple straight serial cable. Such cable is made using a female DB9 connector in each side with the pins 2, 3 and 5 connected directly. See page 16 for cable diagram.

Maximum Allowed Voltage And Power

IMPORTANT

**A maximum power of 1900W at 120V AC for each relay.
A maximum power of 3300W at 220V AC for each relay.**

Power Supply For The CRD300 – CN1

For a reliable performance, a good 12V/130mA DC stabilized power supply is needed when all relays are on.

Please, pay a special attention for the CN1 power supply polarity. Incorrect polarity will damage the board circuits. The correct polarity is marked on the board.

Note

Exceeding the maximum Power allowed for each relay will damage the board and void the warranty.

Operation

The **CRD300** commands were made to be easy to operate and memorize.

Operation Over A Telephone Land Line

Do the following:

- 1) Using a cellular or land line telephone, call the number where the **CRD300** is installed;
- 2) Wait until the **CRD300** answer the call in the first ring¹;
- 3) As soon the call is answered, you should hear beeps indicating the **CRD300** is waiting for commands;
- 4) Dial the password² **123** and wait for three beeps confirming the password³ entered is correct;
- 5) Now you are in command mode and can control any of the outputs;
- 6) Dial **10** to turn the output 1 off. Dial **11** to turn the output 1 on. Check the LED 1 to confirm the output 1 status;
- 7) After send the desired commands, just hang the telephone off to end the operation.

See Page 12 for a complete command list.

Notes

¹ The number of rings for answer is user programmable. See page 14 for details.

² The three digits password is user programmable. See page 14 to learn how to change the password.

³ Exceeding 25 seconds without sending DTMF commands will expire the password validation and the **CRD300** will auto-disconnect.

Operation Over A Cellular Phone

Do the following:

- 1) Using a cellular or land line telephone, call the number where the **CRD300** is installed;
- 2) Wait for the cellular auto-answer mode take place. Normally in the first or second ring;
- 3) Beeps will signalize the **CRD300** is waiting for commands.
- 4) Dial the password¹² **123** and wait for three beeps confirming the password³ entered is correct;
- 5) Now you are in command mode and can control any of the outputs;
- 6) Dial **10** to turn the output 1 off. Dial **11** to turn the output 1 on. Check the LED 1 to confirm the output 1 status;
- 7) After send the desired commands, just hang the telephone off to end the operation.

See Page 12 for a complete command list.

Notes

¹ *The three digits password is user programmable. See page 14 to learn how to change the password.*

² *Exceeding 25 seconds without sending DTMF commands will expire the password validation and the **CRD300** will auto-disconnect.*

Operation Over A Radio Transceiver

Do the following:

- 1) Tune the radio at the same frequency of the radio where the **CRD300** is installed;
- 2) Send the password¹ **123** and wait for three beeps confirming the password² entered is correct;
- 3) Now you are in command mode and can control any of the outputs;
- 4) Dial **10** to turn the output 1 off. Dial **11** to turn the output 1 on. Check the LED 1 to confirm the output 1 status;

See Page 12 for a complete command list.

Notes

¹ Radio transceivers normally have a DTMF keypad in the microphone. To send DTMF command, just press the PTT switch, dial the commands and release the PTT.

² The three digits password is user programmable. See page 14 to learn how to change the password.

Operation Over A RS232 Serial Port

Do the following:

- 1) Open the Microsoft hyperterminal or any kind of software to send text over serial port;
- 2) On settings, choose a free COM port in your computer. Set the speed for 9600, data bits 8, Parity N and Stop Bits 1;
- 3) Click Connect;
- 4) In the text window, write C11 and click send Button;
- 5) You should receiver in the window Response the text R11 confirming the output 1 was turned on successfully;
- 6) To turn the output 1 off, Just send text C10. The Response should be R10.

See Page 13 to a complete serial command list.

Note

*There are some third party softwares and devices to interface an Ethernet port with a serial port. That way you will be able to control the **CRD300** over a local area network or even through the Internet.*

All commands, over telephone or radio, will be confirmed through the serial port.

Command List By Radio Or Telephone

COMMAND	DESCRIPTION	CONFIRMATION
00	All outputs OFF	1 long beep
01	All outputs ON	2 long beeps
10	Output 1 OFF	1 long beep
11	Output 1 ON	2 long beeps
12	Output 1 status	1 long beep or 2 fast beeps
13	Output 1 2s pulse	1 short beep
14	Output 1 10s pulse	1 short beep
15	Output 1 20s pulse	1 short beep
16	Output 1 30s pulse	1 short beep
17	Output 1 60s pulse	1 short beep
20	Output 2 OFF	1 long beep
21	Output 2 ON	2 long beeps
22	Output 2 status	1 long beep or 2 fast beeps
23	Output 2 2s pulse	1 short beep
24	Output 2 10s pulse	1 short beep
25	Output 2 20s pulse	1 short beep
26	Output 2 30s pulse	1 short beep
27	Output 2 60s pulse	1 short beep
30	Output 3 OFF	1 long beep
31	Output 3 ON	2 long beeps
32	Output 3 status	1 long beep or 2 fast beeps
33	Output 3 2s pulse	1 short beep
34	Output 3 10s pulse	1 short beep
35	Output 3 20s pulse	1 short beep
36	Output 3 30s pulse	1 short beep
37	Output 3 60s pulse	1 short beep
40	Output 4 OFF	1 long beep
41	Output 4 ON	2 long beeps
42	Output 4 status	1 long beep or 2 fast beeps
43	Output 4 2s pulse	1 short beep
44	Output 4 10s pulse	1 short beep
45	Output 4 20s pulse	1 short beep
46	Output 4 30s pulse	1 short beep
47	Output 4 60s pulse	1 short beep
51	Input 1 status	1 long beep or 2 fast beeps
52	Input 2 status	1 long beep or 2 fast beeps
52	Input 3 status	1 long beep or 2 fast beeps
8x	Ring numbers selection (1 to 9)	2 short beeps
90	Radio OFF (Output 4 activated)	1 long beep
91	Radio ON (output 4 deactivated)	2 short beeps
95 xxxyyy	Password change (xxx=yyy (000 ~ 999))	3 short/2 short beeps
99	MASTER RESET (password = 123)	5 short beeps

Command List By Serial Port

COMMAND	DESCRIPTION	CONFIRMATION
C00	All outputs OFF	R00
C01	All outputs ON	R01
C10	Output 1 OFF	R10
C11	Output 1 ON	R11
C12	Output 1 status	R12
C13	Output 1 2s pulse	R13
C14	Output 1 10s pulse	R14
C15	Output 1 20s pulse	R15
C16	Output 1 30s pulse	R16
C17	Output 1 60s pulse	R17
C20	Output 2 OFF	R20
C21	Output 2 ON	R21
C22	Output 2 status	R22
C23	Output 2 2s pulse	R23
C24	Output 2 10s pulse	R24
C25	Output 2 20s pulse	R25
C26	Output 2 30s pulse	R26
C27	Output 2 60s pulse	R27
C30	Output 3 OFF	R30
C31	Output 3 ON	R31
C32	Output 3 status	R32
C33	Output 3 2s pulse	R33
C34	Output 3 10s pulse	R34
C35	Output 3 20s pulse	R35
C36	Output 3 30s pulse	R36
C37	Output 3 60s pulse	R37
C40	Output 4 OFF	R40
C41	Output 4 ON	R41
C42	Output 4 status	R42
C43	Output 4 2s pulse	R43
C44	Output 4 10s pulse	R44
C45	Output 4 20s pulse	R45
C46	Output 4 30s pulse	R46
C47	Output 4 60s pulse	R47
C51	Input 1 status	R51x (x can be 0 or 1)
C52	Input 2 status	R52x (x can be 0 or 1)
C53	Input 3 status	R53x (x can be 0 or 1)
C8x	Ring numbers selection (1 to 9)	R8x (x can be 1 to 9)
C90	Radio OFF (Output 4 activated)	R90
C91	Radio ON (output 4 deactivated)	R91
C96	Asks for the password	Rxxx (xxx from 000 to 999)
C97	Software Version	Vx.x
C99	MASTER RESET	R99/PWR
-	On the Power on	PWR
-	When the CRD300 answer the line	RLN

SETUP

The **CRD300** have some user programmable configurations:

Changing The Number Of Rings For Auto-Answer

The **CRD300** comes set to answer the line in the first ring. This value can be change as following:

COMMAND	DESCRIPTION	COMMAND	DESCRIPTION
81	Answer in the first ring	86	Answer in the sixth ring
82	Answer in the second ring	87	Answer in the seventh ring
83	Answer in the third ring	88	Answer in the eighth ring
84	Answer in the fourth ring	89	Answer in the ninth ring
85	Answer in the fifth ring		

Ps: All commands are confirmed by two short beeps.

Changing the Password

- 1) Dial command 95;
- 2) Three beeps will confirm you are in the password change mode;
- 3) Dial the new password twice;
- 4) Three beeps will confirm the new password successfully changed.

If the two entered passwords match, the old password will be changed by the new one. If the passwords not match or an error is made during this process, a long beep will indicate this operation was canceled. In this case, try again. If more than 3s interval occurs between the numbers, the operation is canceled.

PTT/Output 4 Selection

The PTT output pin in the DB9 connector used for radio transceiver transmission activation can be used as a forth output if you use cellular phone or telephone land line. To use as a fourth output, dial 90. A long beep confirms this operation. To use as PTT dial 91. Two short beeps confirm PTT operation.

OUTPUTS BACKUP

The **CRD300** memorizes each relay state in order to remember those states in cases of power failure. Every time you power the **CRD300** on, the last state will be remembered. Output 4 is has no state memory.

MONITORING INPUTS

The **CRD300** feature three independent monitoring inputs. Those inputs can be used to monitor state of alarms, logic circuits or any device you need to know the logic state from distance.

How It Works

Voltage range of 0 ~ 1.7V are considered low (OFF) state.

Voltage range of 1.8V ~ 15V are considered high (ON) state.

Commands over telephone are:

COMMAND	DESCRIPTION	CONFIRMATION
51	Ask state of input 1	Two short beeps/one long beep
52	Ask state of input 2	Two short beeps/one long beep
53	Ask state of input 3	Two short beeps/one long beep

Commands over serial port:

COMMAND	DESCRIPTION	CONFIRMATION
C51	Ask state of input 1	R5x (x can be 0 or 1)
C52	Ask state of input 2	R5x (x can be 0 or 1)
C43	Ask state of input 3	R5x (x can be 0 or 1)

The monitoring inputs pins on CN3:

Input 1 - pin 5

Input 2 - pin 6

Input 3 - pin 7

See CN3 details on Page 16

CN3 CONNECTOR

The CN3 connector is where all signal interface with **CRD300** excepting telephone land line and power supply.

The table below shows each pin function:

PIN	DESCRIPTION	USE
1	DTMF decoding Audio Input (Speaker)	Radio or cellular phone
2	RXD Serial RS-232	Serial Port
3	TXD Serial RS-232	Serial Port
4	Audio output (MIC)	Radio or cellular phone
5	GND	Audio and serial GND
6	Monitor input 1	General use
7	Monitor input 2	General use
8	Monitor input 3	General use
9	PTT/Output 4	Radio or general use

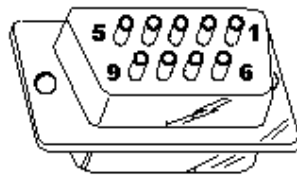

Back view for male DB9 connector

Use male DB9 connector on the **CRD300** side and female DB9 connector on the PC side

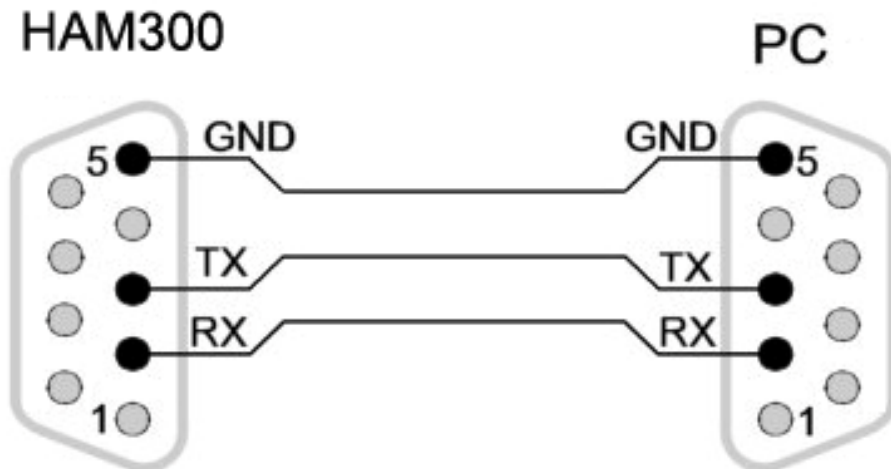

Diagram for a simple straight serial cable (HAM300=CRD300)

Troubleshooting - MASTER RESET

If the **CRD300** operates erratic or not accepting commands, verify:

- All connections, telephone line, cellular, radio or serial port are corrected connected?
- Are you using the correct password?
- When using cellular, is it in auto-answer mode?
- The DTMF LED match with each number dialed?

If you still are not getting control of the **CRD300**, it's possible you are using a wrong password or the software is corrupted. In this case, procedure the following to reset the software to factory configuration and bring back the 123 password:

Through Telephone Land Line

Disconnect the Power from CN1. Using an extension telephone set in the same land line with the **CRD300**, press and hold any DTMF tone in the telephone keypad. Connect the power to the CN1. Wait the PWR LED blink and release the DTMF tone. This procedure should reset to factory defaults and the password will be 123 again.

Through The Serial Port

Send the text command C04 to perform a master reset. This procedure should reset to factory defaults and the password will be 123 again.

Through Cellular

Disconnect the Power from CN1. Press and hold any DTMF key in the cellular keypad. Connect the power to the CN1. Wait the PWR LED blink and release the key. This procedure should reset to factory defaults and the password will be 123 again.

Through Radio

Disconnect the Power from CN1. Send through an extra radio any DTMF tone. Connect the power to the CN1. Wait the PWR LED blink and stops transmitting the tone. This procedure should reset to factory defaults and the password will be 123 again.

Note

When a master reset is properly performed, the PWR LED will blink three times indicating factory reset.

Hamtronix

www.hamtronix.com

© 2008